



VAUCONSANT
CRÉER DE L'APPÉTIT



FILT'AIR DESIGN MOBILE SOLUTION FOR EXTRACTION

With its modern and elegant design, mobile suction hood with shock filter is ideal for efficiently extracting the fumes from your New Front Cooking.

+ PERFORMANCE

With a 900 m³ / h extraction capacity, its shock filter, the activ carbon filter for odor treatment and UV lamp in the air flow to limit bacterial growth, the Filt'Air hood perfectly combines design and performance.

+ CONFORT FOR SERVICE

With LED lighting as standard, the Filt'Air hood provides excellent visibility to the cook.

With a fully acoustically insulated casing, the operation of the hood is really quiet and provides more work comfort for the service.

Capacity

- 900 m³ / h

Possibles configurations

- Mobile
- Inside a counter line

Standards equipments

- LED lighting
- Shock filter
- Activ carbon filter
- UVC Lamp
- Wooden phonic insulation case
- Top in 18/10 AISI 304 stainless steel
- Access door to the filter for easy replacement
- 4 stainless steel swivel castors Ø 100 mm, of which 2 with brakes

Option

- Removable baseboard



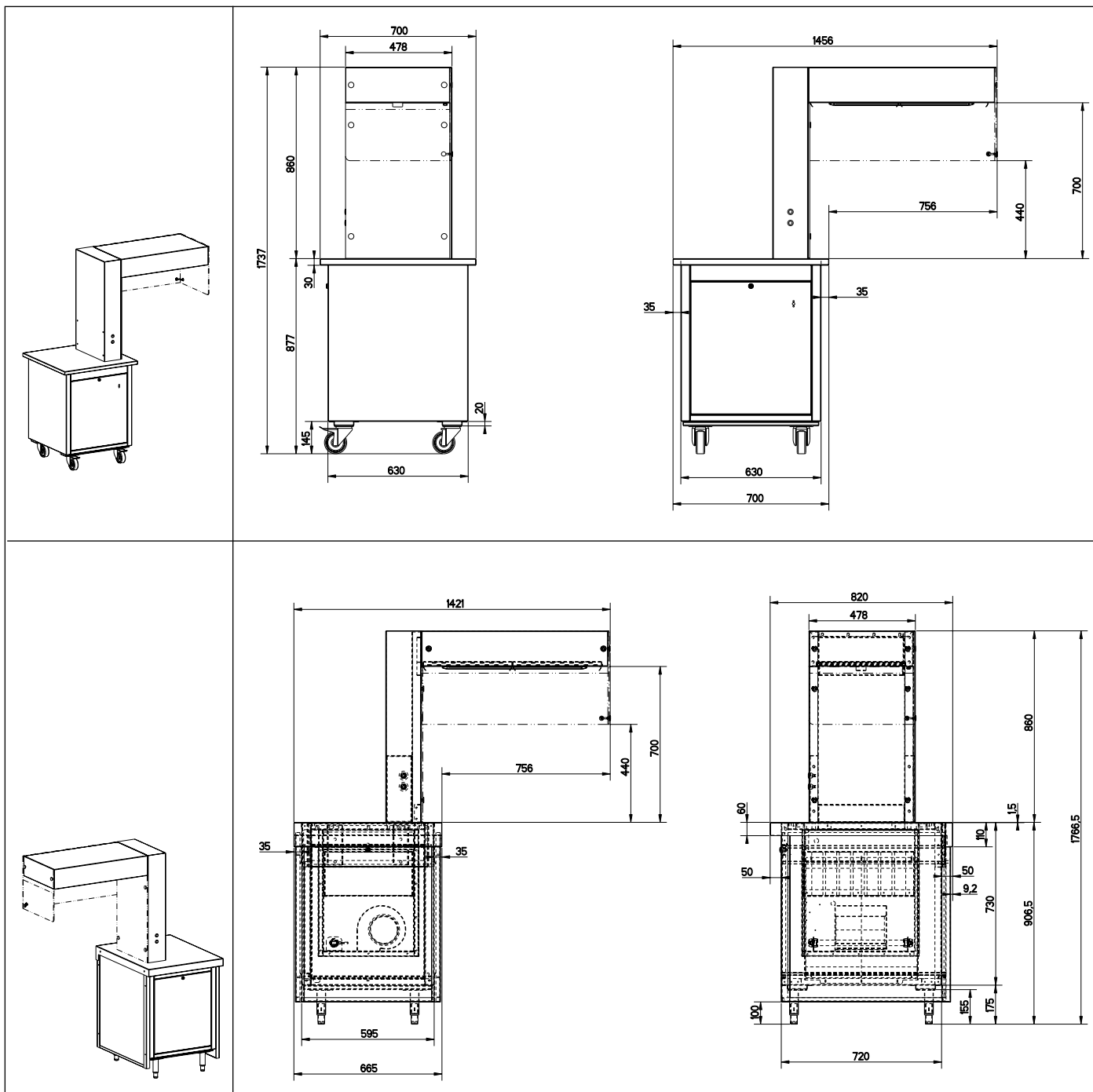

FILT'AIR EXTRACTING HOOD

Configuration		Mobile	Inside a counter line
Capacity		900 m3 / h	900 m3 / h
Length		1462 mm	1462 mm
Width		800 mm	800 mm
Height		1745 mm	1745 mm
Elect. P.		500 W	500 W
Extracting right	Code	MCHT00000	MCHT02000
Extracting left	Code	MCHT01000	MCHT03000
Option			
Removable baseboard	Code	PDF150	